

NOTE:

LOCATE BOTTOM EDGE OF TAPE ABOVE THE ZERO INCH LINE AS FOLLOWS

| | | | |
|-------|---------------|-----|-----------|
| 17.82 | INCHES AT THE | -45 | INCH LINE |
| 17.82 | " | -30 | " |
| 17.82 | " | -15 | " |
| 17.82 | " | 0 | " |
| 17.82 | " | 15 | " |
| 17.82 | " | 30 | " |
| 17.82 | " | 45 | " |

FOR TAPE PART & COLOR NUMBERS SEE DP-43 3569738-3

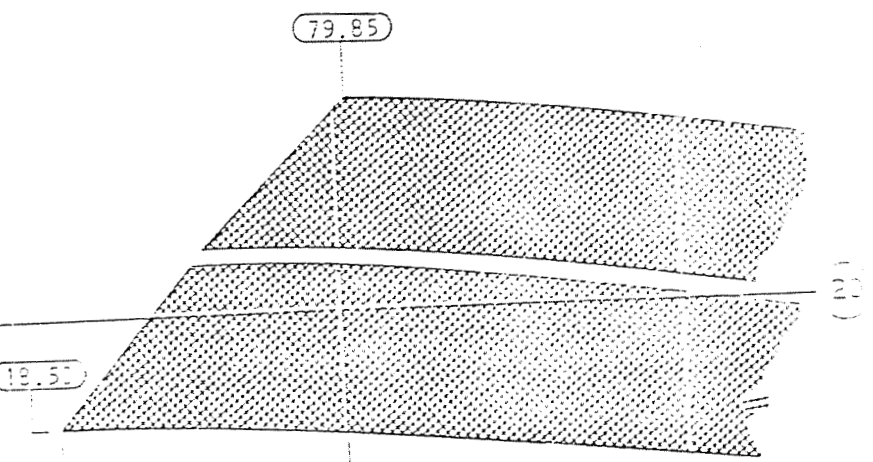
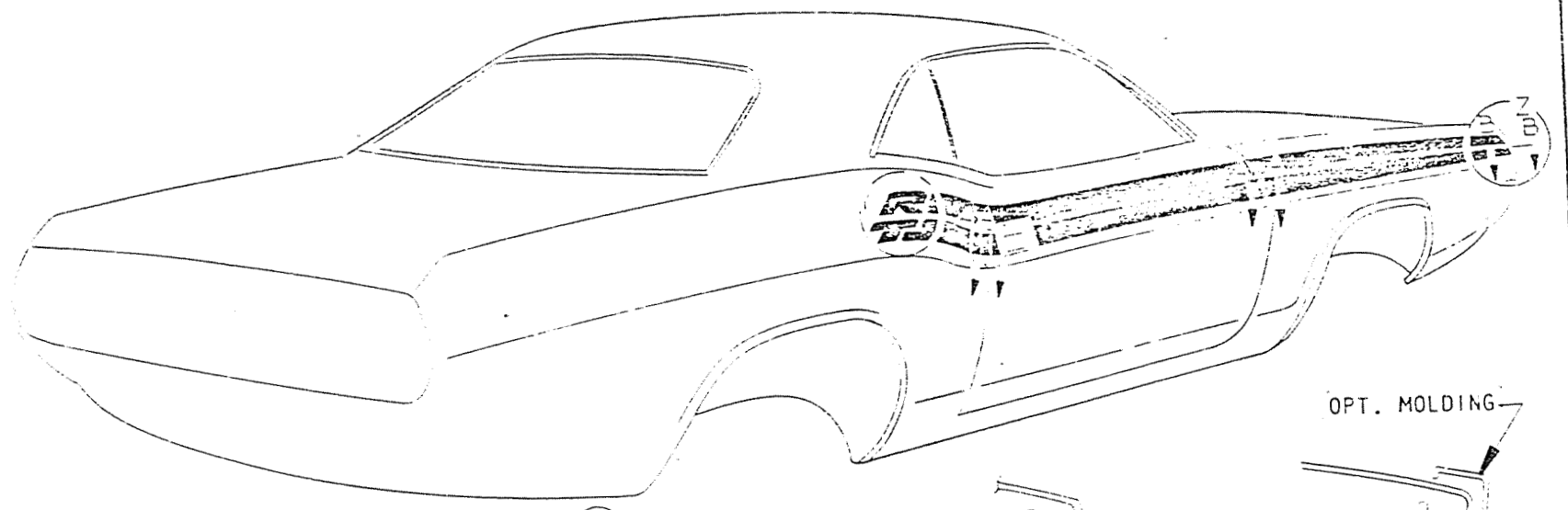

VIEW IN CIRCLE Y
(J-H-00)
#V60/V50

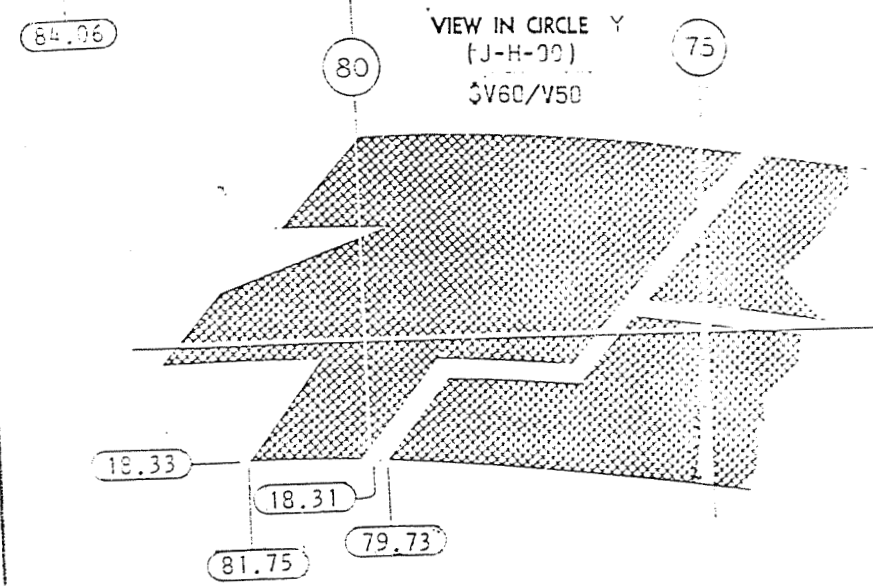

VIEW IN CIRCLE Y
(LT SIDE)
(J-S-00)
#V60/V50

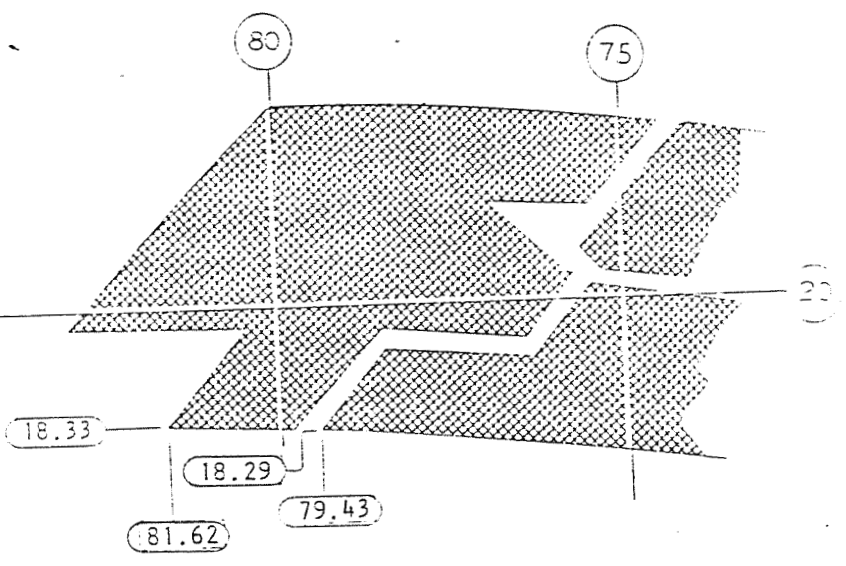

VIEW IN CIRCLE Y
(RT SIDE)
(J-S-00)
#V60/V50

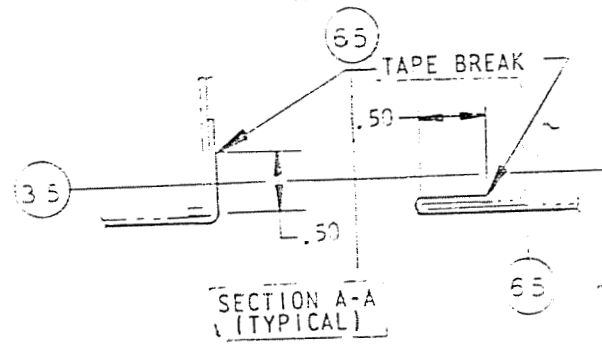

SECTION A-A
(TYPICAL)

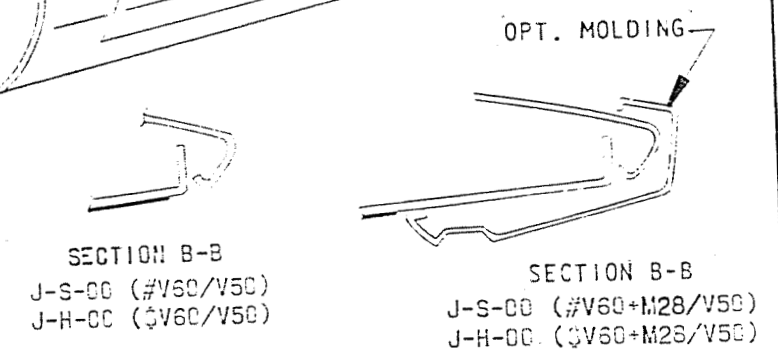

SECTION B-B
J-S-00 (#V60/V50)
J-H-00 (#V60/V50)

SECTION B-B
J-S-00 (#V60+M28/V50)
J-H-00 (#V60+M28/V50)

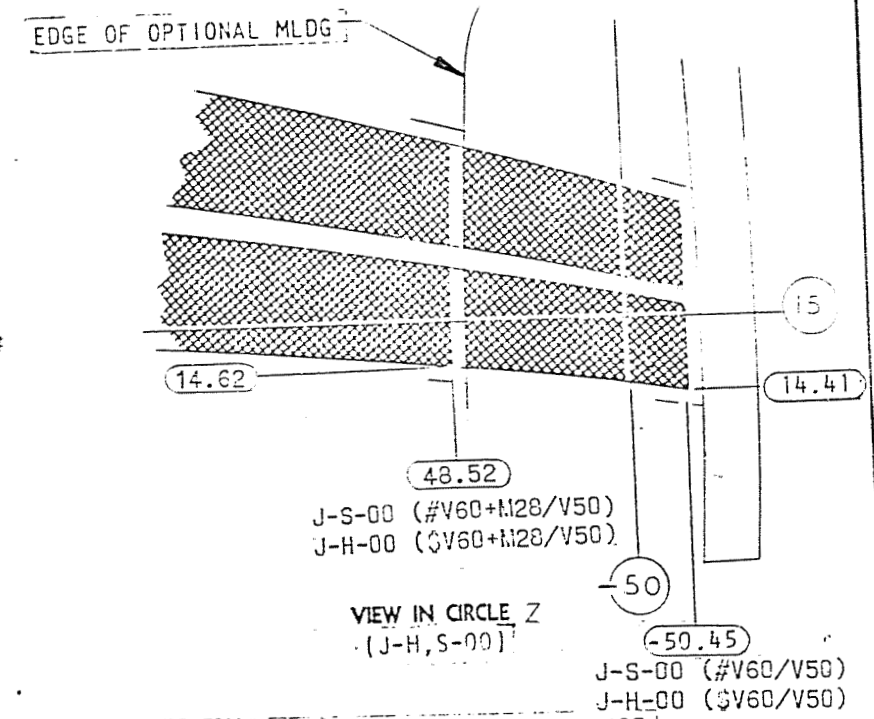

VIEW IN CIRCLE Z
(J-H, S-00)

J-S-00 (#V60/V50)
J-H-00 (#V60/V50)

TAPE OPERATIONS TO BE PERFORMED IN ACCORDANCE WITH P.S. 4993

DECAL OPERATIONS TO BE PERFORMED IN ACCORDANCE WITH P.S. 4941

PAINT

| | | | | | |
|--------------------------|---------|----------|--------------------|--------------------------------------|----------|
| MODELS | | G/J-S-00 | | G/J-H-00 (FOR SALES CODES SEE ABOVE) | |
| DRAWN | CHECKED | APP. | APP. | APP. | DATE |
| MARIS | FAH | RF | | | 10-31-69 |
| ENGINEERING ILLUSTRATION | | | MANUAL NO. 2654909 | | |
| DEPT. 3440 | | | SECTION B | | |
| Tape Stripe-Body Side | | | PAGE 21.0 | | |